

PAGE 1/3	ISSUE 28-04-17A	SERIES ANTENNA	PART NUMBER R380990021
----------	-----------------	----------------	------------------------

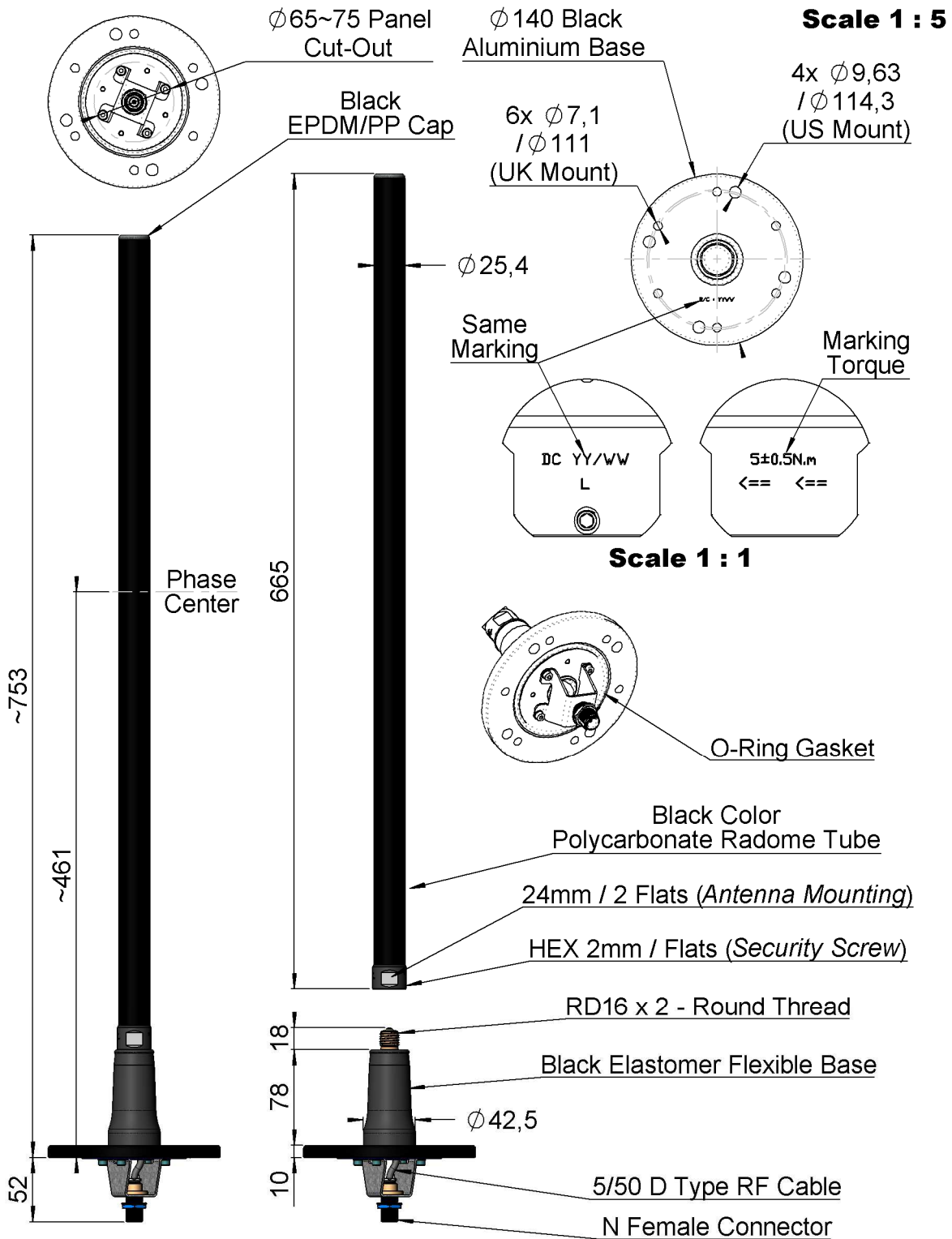

All dimensions are in mm

PAGE 2/3	ISSUE 28-04-17A	SERIES ANTENNA	PART NUMBER R380990021
----------	------------------------	--------------------------	-------------------------------

Part	Material
Radome	Polycarbonate, Black, Matt
Antenna Base	Aluminum, Black
Base Body	Aluminum, Black
Connector bodies	Brass, Black Cr.
Connector Brackett	Aluminum, Black
Insulators	PTFE
Central Contacts	Brass, Ni2Au1.3
Coaxial Cable	Specially developed 5/50Ω coax

The **R380.990.021** is a 70W, Dipolar Design, Broadband Vehicular Antenna. The Phase-Center is located near the middle of the Tubular Radome. The **R380.990.021** is Ground plane Independent Antenna that can be Mast-Mounted without particular impact on Electrical Performances.

ELECTRICAL CHARACTERISTICS

Frequency :	225-512	MHz
Nominal Impedance :	50	Ω
VSWR (225 – 520 MHz) :	2.5:1	Max
	2.0:1	Typ.
Polarization :	VERTICAL	
Radiation Pattern :	OMNIDIRECTIONAL	
Ripple in Azimuth Plane :	±1	dB
Power withstanding :	70	W CW
Connector (Antenna side) :	Custom	
Connector (NATO Base) :	N Female	
Gain (1.2 x 1.2 m ground plane) :	2	dBi (typ.)
Gain in Azimuth plane (1.2 x 1.2 m ground plane) :	1.5±2	dBi

MECHANICAL CHARACTERISTICS

Radome material :	POLYCARBONATE
Finish :	Black, Matt
Weight :	1 Kg
Antenna length (with Elastomer Base) :	~ 800 mm
Antenna Diameter :	~ 25 mm
“Oak” Beam Test :	25 Times @ 40 km/h @ 0.55 m
Wind loading :	> 56 m/s

ENVIRONMENTAL CHARACTERISTICS

Operating temperature :	-55/+71 °C
Storage & transport temperature :	-55/+85 °C
Fluid contamination :	law Mil Std 810G meth. 504.1
Ingress Protection :	IP 67
Salt spray :	96 h law Mil Std 810G, meth. 509.4 (+35°C)
Vibration :	4 cycles of 24h (2 wet and 2 dry, alternatively) law Mil Std 810F, meth. 514.5 proc I, cat.20 (Track & wheeled vehicules)
Shocks :	law Mil Std 810F, meth. 516.5 proc I & V
Solar Radiation :	law Mil Std 810F proc II, desert conditions
Sand & Dust :	law Mil Std 810F proc I & II
Wind Speed :	>56 m/s

PAGE 3/3	ISSUE 28-04-17A	SERIES ANTENNA	PART NUMBER R380990021
----------	-----------------	----------------	------------------------

MOUNTING INSTRUCTIONS

STEP 1:

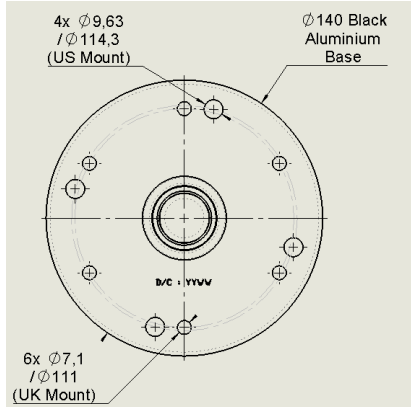

Secure the spring mount on the bracket or on the chassis of the vehicle using one of the two following options:

Option A: use 4 3/8 screws (or eq.) to secure the mount through 4 holes equally spaced on a Ø114.3 mm circle.

Option B: use 1/4 screws (or eq.) to secure the mount through 6 holes located on a Ø111 mm circle

Refer to the technical drawing of the base for more details on both options.

Washers should be used to prevent major scratches that might reduce the mount's compatibility to salt spray.

STEP 2:

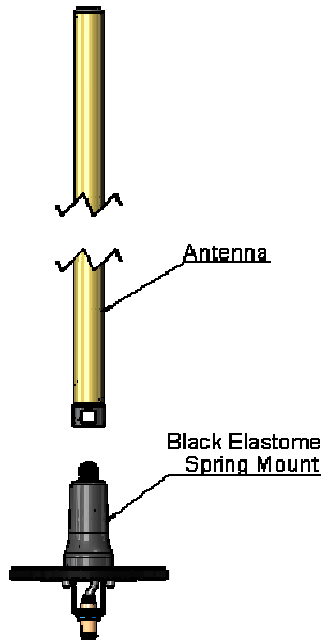

Visually inspect the inner part of the connector of the antenna to make sure no sand, dirt or plastic material will prevent proper electrical mating.

Screw the antenna onto the spring mount until it comes a mechanical stop.

Use torque wrench to tighten antenna to a 5 N.m minimum.

For temperatures lower than -20°C, a torque of 20 N.m shall be used.

STEP 3:

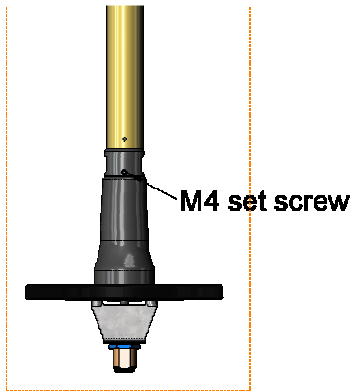

Secure the assembly using the M4 set screw provided with the antenna (2mm Allen Wrench).